

JOB NAME _____
ARCHITECT _____
ENGINEER _____
CONTRACTOR _____
LOCATION _____

SUBMITTAL SHEET
Form Number DS1012 Effective Date 2/97
replaces Form # 3339

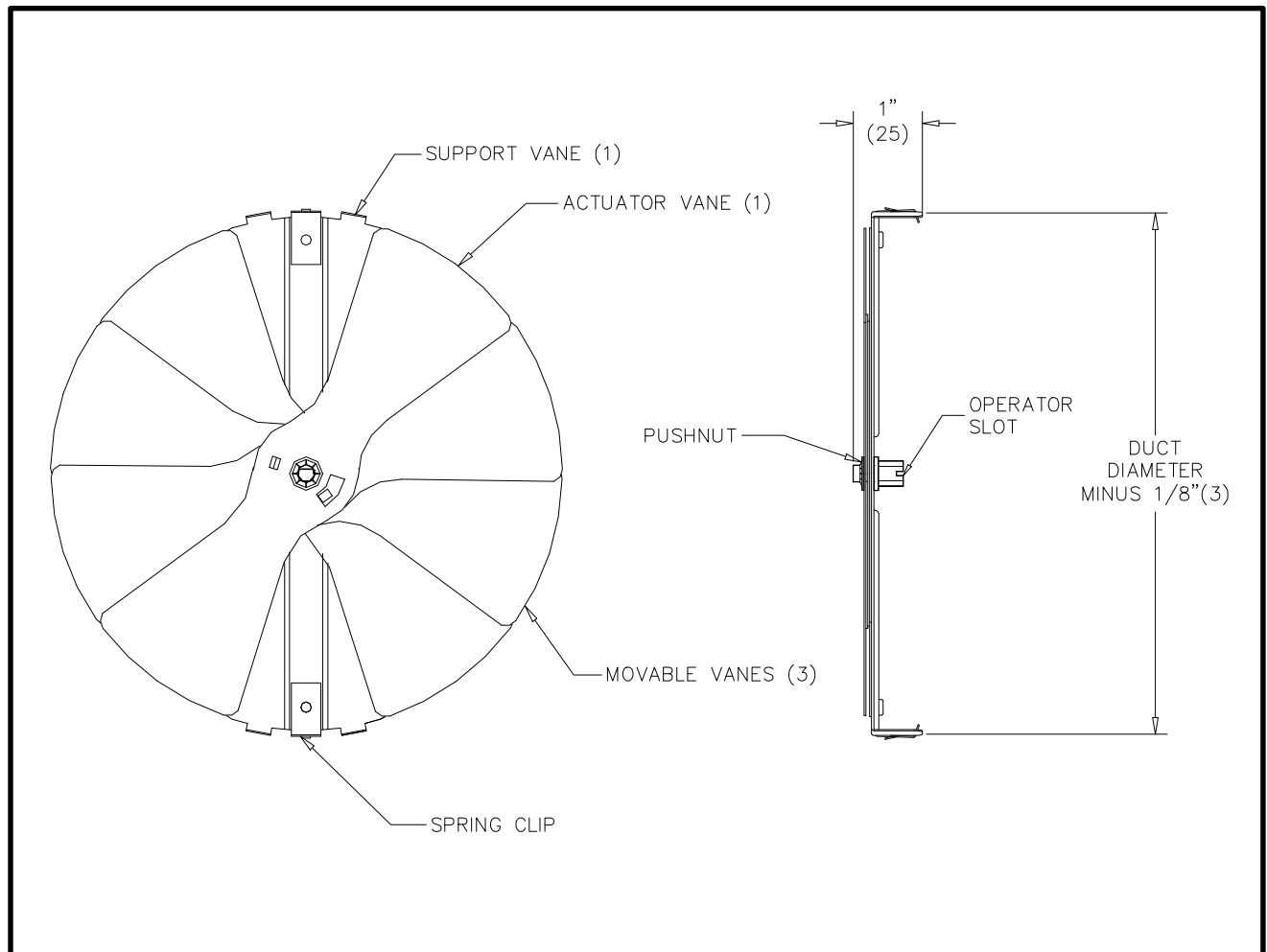

PRN100 SERIES Sliding Blade Damper for Round Neck Diffusers



NOTES:

1. Available sizes are 6", 8", 10", 12", 14.
2. The Krueger PRN100 is a neck mounted radial sliding blade damper for round neck diffusers.
3. Gang operated radial blades which slide at right angles to the duct allowing the damper to work effectively in flexible duct applications.
4. Screwdriver operated.
5. Heavy gauge galvanized steel
6. Standard finish: Mill
7. Field installation is required.
8. Dimensions are in inches.
9. Dimensions in parenthesis are in mm.