

TCI-W-U-H Universal controller with humidity sensor

General description

The TCI-W-U is a stand-alone wall mounted electronic universal controller with two autonomous control loops. Each control loop may use up to 2 PID sequences and 6 binary sequences. The TCI-W11-U features 1 independent control loop, 1 universal input, 2 binary outputs and one analog output, the TCI-W22-U offers 2 independent control loops, 2 universal inputs, 2 binary relays outputs and 1 analog output. A detailed configuration is possible by following a simple setup routine. The TCI can be configured using the standard operation terminal. No special tool or software is required..

Ordering, name convention

tc1-w22-u	Optional functions and housing
Housing	U = 2 x 4" type housing, Blank = square housing
In-/Outputs:	1 = 1UI, 2DOR, 1AO, 2 = 2UI, 2DOR, 1AO
Control loops:	1 = 1 control loop, 2 = 2 control loops
Mounting:	W = Wall mounted
Series Indication	TCI

Item Name	Item Code	Loop	Int. Temp	Int. Humidity	Universal Input	Binary Output	Analog Output	Option
TCI-W11-U	40-10 0074	1	1	0	1	2	1	Standard
TCI-W11-U-H	40-10 0163	1	1	1	1	2	1	RH Sensor 3%
TCI-W11-U-H-A2	40-10 0178	1	1	1	1	2	1	RH Sensor 2%
TCI-W22-U	40-10 0076	2	1	0	2	2	1	Schedules
TCI-W22-U-H	40-10 0078	2	1	1	2	2	1	RH Sensor 3%
TCI-W22-U-H-A2	40-10 0179	2	1	1	2	2	1	RH Sensor 2%

Accessories

AES1-HT-A2	40-50 0067			1				RH Sensor 2%
AES1-HT-A3	40-50 0068			1				RH Sensor 3%
AES1-HT-A5	40-50 0069			1				RH Sensor 5%

Selection of actuators and sensors

Temperature Sensors: Use only our approved NTC sensors to achieve maximum accuracy. Recommended is SDB-Tn10 as duct sensor, SRA-Tn10 as room sensor.

Modulating Actuators: Choose actuators with an input signal type of 0-10V DC or 4-20mA. Minimum and maximum signal limitations may be set in software.

Binary auxiliary devices: E.g. pumps, fans, on/off valves, humidifiers, etc. Do not directly connect devices that exceed the maximum limits as described under technical data. Observe startup current on inductive loads.

Jumper configuration

Jumpers are mounted vertically only.

- AO - Selection of output signal type:
 - Left position: voltage output (0...10 V), *factory default*
 - Right position: current output (0...20 mA)
- AI - Selection of input signal type:
 - Left position: voltage input (0...10 V), *factory default*
 - Middle position: current input (0...20 mA)
 - Right position: RT or dry-contact input

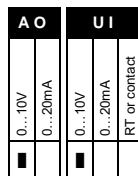

Mounting location

- Install the controller on an easy accessible interior wall, approx. 1.5 m above the floor in an area of average temperature.
- Avoid direct sunlight or other heat sources, e.g. the area above radiators and heat emitting equipment.
- Avoid locations behind doors, outside walls and below or above air discharge grills and diffusers.
- Location of mounting is less critical if external temperature sensors are used.

Installation

- Connect the wires to be connected to the terminals of the power case according to wiring diagram
- Install the mounting plate to the flush mounting box. Make sure that the nipple with the front holding screw is facing to the ground. Make sure the mounting screw heads do not stand out more than 5 mm (0.2") off the surface of the mounting plate.
- Ensure that the jumpers are set correctly.
- Slide the two latches located on the top of the front part into the hooks at the upper side of the mounting plate.
- Carefully lower the front part until the interconnector reaches the mounting-plate. Continue pressing in a gentle way until the front part is fully connected. While inserting the connectors, a slight resistance can be felt. This is normal. Do not use excessive force!
- With a Philips-type screw driver of size #2, carefully tighten the front holding screw to secure the front part to the mounting plate. This screw is located on the front lower side of the unit. There is no need to tighten the screw too much.

Technical specification

Warning! This device is intended to be used for comfort applications. Where a device failure endangers human life and/or property, it is the responsibility of the owner, designer and installer to add additional safety devices to prevent or detect a system failure caused by such a device failure. The manufacturer of this device cannot be held liable for any damage caused by such a failure.

Failure to follow specifications and local regulations may endanger life, cause equipment damage and void warranty.

Power supply	Operating voltage	24 VAC ±10%, 50/60 Hz, class 2, 2.0 A, 48 VA max.
	Power consumption	24 VDC ±10% Max 3 VA
	Electrical connection	Terminal connectors, wire 0.34...2.5 mm ² (AWG 24...12)
	Clock backup	24 hours (deluxe version only)
Signal inputs	Analog inputs	UI1, UI2 DC 0-10V or 0...20mA Input signal Resolution 39 mV or 0.078 mA Impedance Voltage: 98kΩ current: 240Ω
	Temperature inputs	RT internal, external (Sxx-Tn10 sensor) Int. NTC: 0...50 °C (32...122 °F) Ext. NTC: -40...140 °C (-40...284 °F) 0.1 K 40...0 °C (-40...32 °F): 0.5 K 0...50 °C (32...122 °F): 0.2 K 50...100 °C (122...212 °F): 0.5 K > 100 °C (> 212 °F): 1 K
	Humidity sensor AES-HT-Ax:	Capacity sensor Range 0...100 % rH Measuring accuracy See figure below Hysteresis ± 1% Repeatability ± 0.1% Stability < 0.5% / year
	Signal outputs	Analog outputs AO1 Output signal DC 0-10V or 0...20mA Resolution 39 mV, 0.078 mA Maximum load Voltage: ≥ 1kΩ current: ≤ 250Ω
Relays outputs	Type of disconnection	Micro-interruption
	AC voltage	0...48 VAC, 2(1.2)A max. Observe local regulations
	DC voltage	0...30 VDC, 2A max.
Insulation strength	between relays contacts and system electronics:	2000V AC to EN 60 730-1
	between neighboring contacts:	1250V AC to EN 60 730-1
Environment	Operation	To IEC 721-3-3 Class 3 K5
	Climatic conditions	Temperature 0...50 °C (32...122 °F) Humidity <95 % r.H. non-condensing
	Transport & Storage	Climatic Conditions To IEC 721-3-2 and IEC 721-3-1 class 3 K3 and class 1 K3 Temperature -25...70 °C (-13...158 °F) Humidity <95 % r.H. non-condensing Mechanical conditions class 2M2
Standards	conform according to EMC standard	EN 61 000-6-1/ EN 61 000-6-3
	EMEI standard 73/23/EEC	
Product standards	Automatic electrical controls for household and similar use	EN 60 730 -1
	Special requirement on temperature dependent controls	EN 60 730 - 2 - 9
Degree of protection		IP30 to EN 60 529
	Pollution class	II (EN 60 730-1)
Safety class		III (IEC 60536)
	Overvoltage category	I (EN 60 730-1)
Housing	Materials: Cover, back part	Fire proof ABS plastic (UL94 class V-0)
	Mounting plate	Galvanized steel
General	Dimensions (H x W x D)	Front part: 112 x 73 x 15 mm (4.4" x 2.9" x 0.6") Power case: ø 58 x 32 mm (ø 2.3" x 1.3")
	Weight (including package)	TCI-W11-U = 255g (9,0 oz) TCI-W22-U = 265g (9,3 oz)

Power failure

Upon power-interruption, all parameters and set points are memorized in non-volatile memory, and therefore do not have to be re-entered.

Error messages

- Err1:** An assigned input is not enabled or missing. All control loops, functions and outputs tied to this input will be disabled. Verify input connections, jumper settings and parameter settings for the input involved.
- Err3:** A function refers to a disabled input. Disable the function or enable the input.
- Err4:** Internal failure. Product must be replaced.

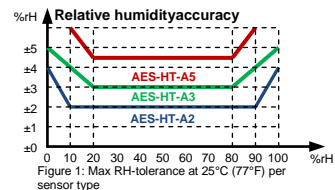
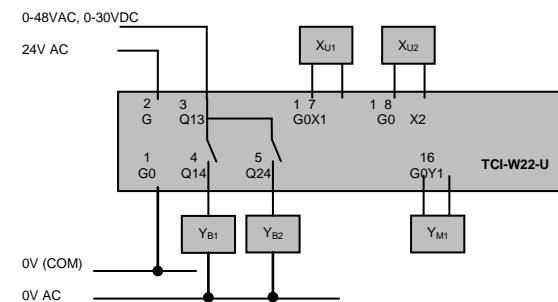
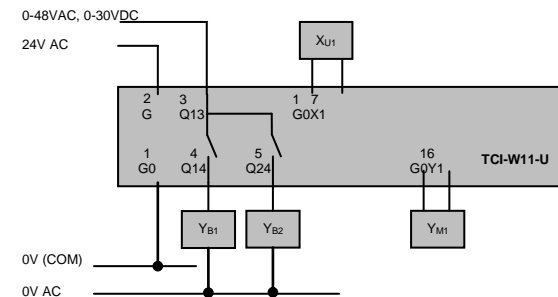

Figure 1: Max RH-tolerance at 25°C (77°F) per sensor type

Wiring diagram

Warning: Live electrical components

During installation, testing, servicing and troubleshooting of Vector Controls products, it may be necessary to work with live electrical components. Have a qualified licensed electrician or other individual who has been properly trained in handling live electrical components perform these tasks. Failure to follow all electrical safety precautions when exposed to live electrical components could result in death or serious injury.



Description

G0	Power supply:	0V, -24VDC; common for power supply, analog in- and outputs
G	Power supply:	24VAC, +24VDC
Q...	Binary outputs:	Potential free relays output (See technical Specification)
Xu...	Universal input:	NTC 10KΩ @ 25°C (77°F), 0...10 V or 0...20 mA
Y...	Analog output:	0...10 V or 0...20 mA
Xt1	Internal temperature input	
Xh1	Internal humidity input:	only for TCI-W22-U-H models

Dimensions mm (inch)

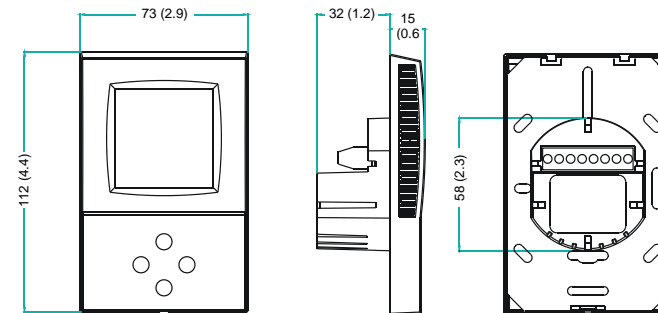

Controller configuration

Proceed in the following steps in order to adapt the controller to its application:

1. Set jumpers for inputs and outputs
2. Connect power supply and inputs
3. Program input parameters
4. Program control parameters
5. Program output parameters
6. Test function of unit
7. Switch off power
8. Connect outputs
9. Test control loop
10. Set user settings

Configuration parameters for firmware version 1.1

The TCI-W-U can be adapted to wide variety of applications. The adaptation is done with parameters. The parameters can be changed on the unit without the need of additional equipment.

Identifying the firmware version

The parameters and functionality of controller depend on its firmware revision. It is therefore important to use a matching product version and parameter set. The firmware version is marked on the package box of your product. In order to identify the firmware version of an installed controller, press UP and DOWN keys simultaneously for three seconds: The display will indicate the firmware version in the upper large digits and the revision in the lower small digits. Press the LEFT key to return to normal operation.

Identifying the firmware version

The parameters and functionality of controller depend on its firmware revision. It is therefore important to use a matching product version and parameter set. The firmware version is marked on the package box of your product. In order to identify the firmware version of an installed controller, press UP and DOWN keys simultaneously for three seconds: The display will indicate the firmware version in the upper large digits and the revision in the lower small digits. Press the LEFT key to return to normal operation.

Changing the parameters

1. Press UP and DOWN button simultaneously for three seconds. The display will indicate the firmware version in the upper large digits and the revision in the lower small digits. Press the RIGHT or POWER key to start login
2. CODE is shown in small display.
3. The code for accessing the user parameters is 0009, for control parameters it is 0241
4. Select this using UP or DOWN buttons.
5. Press the RIGHT or POWER button after selecting the correct code.
6. Once logged in the parameter group can be selected with the UP and DOWN key. Enter the group with the RIGHT or POWER key.
7. Once the group is selected, the parameter is displayed immediately
8. Select the parameters with the UP/DOWN buttons. Change a parameter by pressing the RIGHT button. Arrows 8 to 10 show up and indicate that the parameter may be modified now. Use UP or DOWN buttons to adjust the value.
9. After you are done, press RIGHT or POWER in order to save the new value of the parameter and return to the selection level. Pressing LEFT key will discard the value and return to the selection menu without saving.
10. Press the LEFT key again so as to leave the parameter menu and return to the group selection. Press LEFT key again while in the group selection to return to normal operation.
11. The unit will return to normal operation if no key is pressed for more than 5 minutes.

User parameters (password 09)

Parameter	Description	Range	Default
UP 00	Enable access to operation modes	ON, OFF	ON
UP 01	Enable access to set points	ON, OFF	ON
UP 02	Enable manual control in cascade or fan control mode	ON, OFF	ON
UP 03	Enable change of heating/cooling mode for 2 pipe systems	ON, OFF	ON
UP 04	Enable access to time programs:	ON, OFF	ON
UP 05	State after power failure: 0= off, 1= on, 2= state before power failure	0, 1, 2	2
UP 06	Enable Economy (unoccupied) Mode. Shift the set point to a lower temperature in winter or higher temperature in summer in order to save energy. Economy mode may be activated through the POWER button, or with the external input (typically for key card switches in hotel rooms or motion detectors for meeting rooms.)	ON, OFF	OFF
UP 07	Celsius or Fahrenheit: ON= Fahrenheit, OFF= Celsius	ON, OFF	OFF (Celsius)
UP 08	Show standard display while no key is pressed	ON, OFF	ON
UP 09	Select contents of Large LCD display in standard mode: 00 = OFF 01 = Input 02 = Set point 03 = Analog Output 04 = Binary Output 05 = Clock	0...5	1
UP 10	Select ID of contents of upper digit display: Input: 1= 1T 2= 1H 3= 1U 4= 2U Set point: 1= Lp1 2= Lp2 Analog or floating output: 1 = AO1 2 = FO1 Binary output: 1 - DO1 2 - DO2	0...4	2
UP 11	Select contents of lower digit display in standard mode	0...5	TCI-W11 = 2 TCI-W22 = 5
UP 12	Select ID of contents of lower digit display	0...4	1
UP 13	Select analog output for display in vertical bar 00 = OFF 01 = AO1 02 = FO1 03 = Output lp1 04 = Output lp2	0...4	3
UP 14	Display heating/cooling state in standard display mode	ON, OFF	OFF
UP 15	ON = Alarms blink after being active and need to be confirmed OFF = Alarms are only shown when they are active	ON, OFF	ON
UP 16 (TCI-W22)	Clock display type: OFF= 24-hr, ON= 12-hr (AM/PM)	ON, OFF	OFF
UP 17 (TCI-W22)	Reset timer for manual override of time schedule: 0= Not active 1-255= Delay in Minutes in case the controller is manually switched on in scheduled off or economy mode. The controller will return to scheduled function after expiration of this delay.	0...255	60 (Min)

Control parameters (password 241)

Warning! Only experts should change these settings! The parameters are grouped according to control modules. After completing the logging in, a control module must be selected before accessing the parameters.

Module	Description
UI	Input configuration: 1T, 1H, 1U, 2U
LP	Control loops Lp1, Lp2
AO	Analog output configuration, AO1
DO	Binary output configuration, do1, do2
FU	Special functions

Internal input configuration (I11)

Parameter	Description	Range	Standard
1t 00	Enable internal sensor	ON, OFF	OFF
1t 01	Display minimum value	-50...205	0
1t 02	Display maximum value	-50...205	100
1t 03	Sensor sampling rate (control speed decrease as rate increases)	0...100	10
1t 04	Sensor calibration	-10.0...10.0	0
1t 05	Alarm 1 low limit (1T), Alarm 3 low limit (1H)	OFF, ON	OFF
1t 06	Alarm 1/3 low limit values	-50...205 °C	5°C (41°F)
1t 07	Alarm 2 high limit (1T), Alarm 4 high limit (1H)	OFF, ON	OFF
1t 08	Alarm 2/4 high limit values	-50...205 °C	50°C (122°F)
1t 09	Hysteresis Alarm 1, 2, 3, 4	0...100 °C	5°C (10°F)
1t 10	Calculate a range of inputs (0= not active): 1= average, 2= minimum, 3= maximum	0 - 3	0

Internal input configuration (H11)

Parameter	Description	Range	Standard
1H 00	Enable internal sensor	ON, OFF	ON
1H01	Display minimum value	-50...205	0
1H02	Display maximum value	-50...205	100
1H03	Sensor sampling rate (control speed decrease as rate increases)	0...100	10
1H04	Sensor calibration	-10.0...10.0	0
1H05	Alarm 1 low limit (1T), Alarm 3 low limit (1H)	OFF, ON	OFF
1H06	Alarm 1/3 low limit values	0...100%	5%
1H07	Alarm 2 high limit (1T), Alarm 4 high limit (1H)	OFF, ON	OFF
1H08	Alarm 2/4 high limit values	0...100%	95%
1H09	Hysteresis Alarm 1, 2, 3, 4	0...100%	5%
1H10	Calculate a range of inputs (0= not active): 1= average, 2= minimum, 3= maximum	0 - 3	0

Universal input configuration (U1, U2)

Parameter	Description	Range	Standard
1u 00	Signal type (0= not active): 1= 0-10V or 0-20mA, 2= 2-10V or 4-20mA, 3= passive temperature	0 - 3	0
1u 01	Display minimum value	-50...205	0
1u 02	Display maximum value	-50...205	100
1u 03	Analog input display range: 0=x0.1, 1=x1, 2=x10, 3=x100	0 - 2	1
1u 04	Analog input unit of measure: 0= no unit, 1= %, 2= °C/°F, 3= Pa	0 - 3	2
1u 05	Sensor sampling rate (control speed decrease as rate increases)	0...100	10
1u 06	Sensor calibration	Range dep	0
1u 07	Alarm 5 low limit (1U)	OFF, ON	OFF
1u 08	Alarm 5 low limit value	-50...205 °C	5°C (41°F)
1u 09	Alarm 6 high limit (1U)	OFF, ON	OFF
1u 10	Alarm 6 high limit value	-50...205 °C	50°C (122°F)
1u 11	Hysteresis alarm 5 and 6	0...100 °	5°C (10°F)
1u 12	Calculate a range of inputs (0=not active): 1= average, 2= minimum, 3= maximum, 4= differential	0 - 4	0

LP: Control parameters (1L)

Parameter	Description	Range	Standard
1L 00	Select loop control input (0= loop disabled): 1= 1T, 2= 1H, 3= 1U, 4= 2U	0-4	2
1L 01	Minimum set point limit heating	per input	10%
1L 02	Maximum set point limit heating	per input	90%
1L 03	Minimum set point limit cooling	per input	10%
1L 04	Maximum set point limit cooling	per input	90%
1L 05	Enable set point compensation (0= disabled) 1= winter compensation, 2= summer compensation, 3= winter and summer	0-3	0
1L 06	Loop input special (0= normal): 1= combine loop 1 and loop 2 2= cascade with reverse sequence of primary loop 3= cascade with direct sequence primary loop 4= cascade with both reverse and direct sequence of primary loop	0-4	0
1L 07	Economy mode set point shift: (Function depends on 1L25) The comfort (occupied) set point is shifted by the value set with parameter. Reduces the heating set point and increases the cooling set point.	per input	10%
1L 08	Dead zone between heating and cooling set points The Dead Zone Span lies between the heating and the cooling set point. The output is off while the measured value is within the dead zone span. A negative dead zone is not possible.	Per input	5%
1L 09	Offset for heating PI sequence	per input	0
1L 10	Offset for cooling PI sequence	per input	0
1L 11	P-band heating	per input	10%
1L 12	P-band cooling	per input	10%
1L 13	Integral gain heating (0.1 steps) low= slow reaction, high= fast reaction	0-25.5	0.0
1L 14	Integral gain cooling (0.1 steps)	0-25.5	0.0
1L 15	Measuring interval integral (seconds) low= fast reaction, high value= slow reaction	0-255	1 sec.
1L 16	Action of stages: 0= cumulative: stage 1 stays on when 2 on comes on 1= single: stage 1 turns off when 2 on comes on 2= digital: stage 1 only, stage 2 only, then stage 1 plus 2	0-2	0
1L 17	Offset for heating/reverse binary sequences	per input	0%
1L 18	Offset for cooling/direct binary sequences	per input	0%
1L 19	Switching span heating	per input	10%
1L 20	Switching span cooling	per input	10%
1L 21	Switching hysteresis	per input	5%
1L 22	Switching delay	0-255s	30s
1L 23	Activation of reverse/direct (heat/cool) sequence OFF= activates based on demand ON= follows heat/cool state of controller	ON/OFF	OFF
1L 24	Delay for heat /cool changeover when L23=OFF	0-255 min	5 min
1L 25	Fixed set point in standby mode OFF = Standby set point shift applies ON = In standby mode use minimum set point limit as set point in heating mode or maximum set point limit in cooling mode	ON, OFF	OFF
1L 26	Set point compensation range, the maximum range the set point is shifted. 0 = Temperature setback: the set point is shifted towards set point limit	Acc input	0%

LP: Control parameters (2L)

Parameter	Description	Range	Standard
2L 00	Select loop control input (0= loop disabled): 1= 1T, 2= 1H, 3= 1U, 4= 2U	0-4	0
2L 01	Minimum set point limit heating	per input	10°C(50°F)
2L 02	Maximum set point limit heating	per input	28°C(82°F)
2L 03	Minimum set point limit cooling	per input	18°C(64°F)
2L 04	Maximum set point limit cooling	per input	34°C(93°F)
2L 05	Enable set point compensation (0= disabled) 1= winter compensation, 2= summer compensation, 3= winter and summer	0-3	0
2L 06	Loop input special (0= normal): 1= combine loop 1 and loop 2 2= cascade with reverse sequence of primary loop 3= cascade with direct sequence primary loop 4= cascade with both reverse and direct sequence of primary loop	0-4	0
2L 07	Economy mode set point shift: (Function depends on 2L25) The comfort (occupied) set point is shifted by the value set with parameter. Reduces the heating set point and increases the cooling set point.	per input	5.0°C(10°F)
2L 08	Dead zone between heating and cooling set points The Dead Zone Span lies between the heating and the cooling set point. The output is off while the measured value is within the dead zone span. A negative dead zone is not possible.	Per input	1.0°(2°F)

2L 09	Offset for heating PI sequence	per input	0
2L 10	Offset for cooling PI sequence	per input	0
2L 11	P-band heating	per input	2.0°C(4.0°F)
2L 12	P-band cooling	per input	2.0°(4.0°F)
2L 13	Integral gain heating (0.1 steps) low= slow reaction, high= fast reaction	0-25.5	0.0
2L 14	Integral gain cooling (0.1 steps)	0-25.5	0.0
2L 15	Measuring interval integral (seconds) low= fast reaction, high value= slow reaction	0-255	1 sec.
2L 16	Action of stages: 0= cumulative: stage 1 stays on when 2 on comes on 1= single: stage 1 turns off when 2 on comes on 2= digital: stage 1 only, stage 2 only, then stage 1 plus 2	0-2	0
2L 17	Offset for heating/reverse binary sequences	per input	0.0°(0.0°F)
2L 18	Offset for cooling/direct binary sequences	per input	0.0°(0.0°F)
2L 19	Switching span heating	per input	1.0°(2.0°F)
2L 20	Switching span cooling	per input	1.0°(2.0°F)
2L 21	Switching hysteresis	per input	0.5°(1.0°F)
2L 22	Switching delay	0-255s	10s
2L 23	Activation of reverse/direct (heat/cool) sequence OFF= activates based on demand ON = follows heat/cool state of controller	ON/OFF	OFF
2L 24	Delay for heat /cool changeover when L23=OFF	0-255 min	5 min
2L 25	Fixed set point in standby mode OFF = Standby set point shift applies ON = In standby mode use minimum set point limit as set point in heating mode or maximum set point limit in cooling mode	ON, OFF	OFF
2L 26	Set point compensation range, the maximum range the set point is shifted. 0 = Temperature setback: the set point is shifted towards set point limit	Acc input	0.0°C

Analog output

Parameter	Description	Range	Standard
1A 00	Select control loop or special function (0= OFF): 1= LP1, 2= LP2 3= Dehumidify (4 pipe, max LP1 cooling, LP2 direct) 4= Manual positioning or time schedule controlled(0-100%) 5= Transmit value of an input	0 - 5	1
1A 01	When 1A00=1 configure output: 0= Heating/reverse 1= Cooling/direct 2= Heating and cooling (2 pipe) 3= Transmit set point When 1A00 = 4 Manual positioning or time schedule controlled 0 = time schedule controlled only 1 = manual positioning and time schedule controlled When 1A00=5, select input (0= function disabled): 1= 1T, 2= 1H, 3= 1U, 4= 2U	0 - 4	0
1A 02	Type of output signal: OFF= 0-10V, 0-20mA, ON= 2-10V, 4-20mA	ON, OFF	OFF (0-10V, 0-20mA)
1A 03	Minimum limitation of output signal default and in loop heating mode	0 - 100 %	0
1A 04	Maximum limitation of output signal default and in loop heating mode	0 - 100 %	100%
1A 05	Minimum limitation of output signal in loop cooling mode	0 - 100%	0%
1A 06	Maximum limitation of output signal in loop cooling mode	0 - 100 %	100%
1A 07	Choose alarm to set output to 100% (output 0% on conflicting alarms) Alarm: 1 2 3 4 5 6 7 8 ▽▽▽▽▽▽▽▽	Selection	▽▽▽▽▽▽▽▽
1A 08	Choose alarm to set output to 0%. (output 0% on conflicting alarms) Alarm: 1 2 3 4 5 6 7 8 ▽▽▽▽▽▽▽▽	Selection	▽▽▽▽▽▽▽▽
1A 09	Transmit value (1A00=5): minimum input value	Acc input	-
1A 10	Transmit value (1A00=5): maximum input value	Acc input	-

Binary output – 3-point control

Parameter	Description	Range	Standard
1d 00	Enable digital or floating point output OFF= 1d and 2D are two digital outputs ON = 1d and 2D are one floating point output (1d open, 2D close)	ON, OFF	OFF
1d 01	Select control loop or special function (0= OFF) 1= LP1, 2= LP2 3= Dehumidify (4 pipe, max LP1 cooling, LP2 direct) 4= Manual positioning (open/close) 5= Controller state functions	0...5	0
1d 02	If 1d01=1 configure output: 0= Heating/reverse 1= Cooling/direct 2= Heating and cooling (2 pipe) If 1d01 = 4 Manual positioning or time schedule controlled 0 = time schedule controlled only 1 = manual positioning and time schedule controlled If 1d01=5 select state functions: 0= ON if controller operation state is ON 1= ON while demand on any output 2= ON while controller in heating mode and operation state ON 3= ON while controller in cooling mode and operation state ON	0...5	0
1d 03	Running time (from open to close)	0 – 255s	90s
1d 04	Switching difference for floating point signal	0 – 100s	5s
1d 05	Not used	0 – 1275 s	0s
1d 06	Choose alarm to set output to 100% (output 0% on conflicting alarms) ▽▽▽▽▽▽▽▽ Alarm: 1 2 3 4 5 6 7 8	Selection	▽▽▽▽▽▽▽▽
1d 07	Choose alarm to set output to 0% (output 0% on conflicting alarms) ▽▽▽▽▽▽▽▽ Alarm: 1 2 3 4 5 6 7 8	Selection	▽▽▽▽▽▽▽▽
1d 08	Not used	ON, OFF	OFF
1d 09	Not used	ON, OFF	OFF

Binary output – Binary control

Parameter	Description	Range	Standard
1d 00	Enable digital or floating point output OFF= 1d and 2D are two digital outputs ON = 1d and 2D are one floating point output (1d open, 2D close)	ON, OFF	OFF
1d 01	Select control loop or special function (0= OFF) 1= LP1 2= LP2 3= Dehumidify (4 pipe, max LP1 cooling, LP2 direct) 4= Manual positioning (on/off) 5= State functions	0...5	0
1d 02	When 1d01=1, configure output: 0= Stage 1 heating/reverse 1= Stage 1 cooling/direct 2= Stage 1 heating and cooling, reverse and direct 3= Stage 2 heating/reverse 4= Stage 2 cooling/direct 5= Stage 2 heating and cooling, reverse and direct If 1d01 = 4 Manual positioning or time schedule controlled 0 = time schedule controlled only 1 = manual positioning and time schedule controlled When 1d01=5, select state functions: 0= ON if controller operation state is ON 1= ON while demand on any output 2= ON while controller in heating mode and operation state ON 3= ON while controller in cooling mode and operation state ON	0...5	0
1d 03	Switch-off delay (time output active with no more demand) Delay is in seconds or minutes depending on d09	0 – 255s	90s
1d 04	Switch-on delay (time demand active before output on) In state mode 1d01=5 outputs disabled during switch-on delay Delay is in seconds or minutes depending on d09	0 – 255s	5s
1d 05	Activate PWM, set cycle time, seconds (>0 activates, 0 deactivates)	0 – 1275s	0s
1d 06	Choose alarm to set output to ON (output OFF on conflicting alarms) ▽▽▽▽▽▽▽▽ Alarm: 1 2 3 4 5 6 7 8	Selection	▽▽▽▽▽▽▽▽
1d 07	Choose alarm to set output to OFF (output OFF on conflicting alarms) ▽▽▽▽▽▽▽▽ Alarm: 1 2 3 4 5 6 7 8	Selection	▽▽▽▽▽▽▽▽
1d 08	Display fan symbol while active	ON, OFF	OFF
1d 09	Binary switching delays in minutes or seconds OFF = delays are in seconds, ON = delays are in minutes	ON, OFF	OFF

Special functions – SP compensation

Parameter	Description	Range	Standard
Fu 00	Select compensation input (0= function disabled): 1= 1T, 2= 1H, 3= 1U, 4= 2U	0...4	0
Fu 01	Winter compensation set point setback OFF= shift toward control loop heating set point minimum ON= shift toward control loop heating set point maximum	ON, OFF	OFF
Fu 02	Winter compensation lower limit value – end shift	Range acc input	5°C
Fu 03	Winter compensation upper limit value – start shift	Range acc input	20°C
Fu 04	Summer compensation set point setback OFF= shift toward control loop cooling set point minimum ON= shift toward control loop cooling set point maximum	ON, OFF	ON
Fu 05	Summer compensation lower limit value – start shift	Range acc input	35°C
Fu 06	Summer compensation upper limit value – end shift	Range acc input	40°C
Fu 07	Show hot/cool symbol while compensation active	ON, OFF	OFF

Special functions – Remote control comfort – economy

Fu 08	Select comfort/economy changeover input (0= disabled): 1= 1T, 2= 1H, 3= 1U, 4= 2U	0...4	0
Fu 09	Economy activation delay (seconds)	0 – 1275 s	300s
Fu 10	Input limit 1	Range acc input	10
Fu 11	Input limit 2	Range acc input	90

Special functions – Remote control enable – disable

Fu 12	Select enable-disable input (0= function disabled): 1= 1T, 2= 1H, 3= 1U, 4= 2U	0...4	0
Fu 13	Manual override permitted (without waiting for delay). This function allows starting the controller; although the enable conditions are not met. The controller will switch off again if the running conditions are not met until the disable delay is expired.	ON, OFF	OFF
Fu 14	Enable delay (seconds)	0 – 1275 s	0
Fu 15	Disable delay (seconds)	0 – 1275 s	300
Fu 16	Range of limits: OFF = When limit 2 is greater than limit 1, enable when input value is greater than limit 2, disable when input value is less than limit 1. When limit 2 is less than limit 1, enable when input value less than limit 1, disable when input value is greater than limit 2. ON = When limit 2 is greater than limit 1 enable when input value is between limit 1 and limit 2. When limit 2 is less than limit 1, enable when input value below limit 2 or above limit 1	ON, OFF	OFF
Fu 17	Input limit 1	Range acc input	10
Fu 18	Input limit 2	Range acc input	90
Fu 19	Disable in case of alarms	Selection	▽▽▽▽▽▽▽▽

Special functions – Remote heat / cool (reverse / direct) change

Fu 20	Select heat/cool changeover input (0= function disabled): 1= 1T, 2= 1H, 3= 1U, 4= 2U, 5= h/c status loop 1, 6= h/c status loop 2	0...6	0
Fu 21	Cooling activation delay (seconds)	0 – 1275 s	300
Fu 22	Input limit 1	Range acc input	20
Fu 23	Input limit 2	Range acc input	40