



C.W. O'DELL ASSOCIATES INC.

# the BEE line



WINTER 1995

VOLUME 9 ISSUE 1

## T.A. MORRISON APPOINTS C.W. O'DELL AS THEIR EXCLUSIVE REPRESENTATIVE



seasons greetings

Tamco dampers are a cost effective solution to reducing:

- ◆ unwanted outside air
- ◆ energy costs
- ◆ humidification costs
- ◆ heat loss
- ◆ frost penetration

Tamco "Dual-Bearing System" has proven service life of 20 years plus.

Comparative cost of ownership for Tamco Damper shown on back.

In the next few weeks we will be around to drop off a new Tamco catalogue to your office.

*NOTE: Our office will be open December 27 & 28, 1995.*

### DID YOU KNOW ?

- ◆ Belimo linkage hardware makes replacements easy when direct coupling is not possible
- ◆ Belimo can replace Honeywell Electronic series 90 or 0-135 OHM controllers

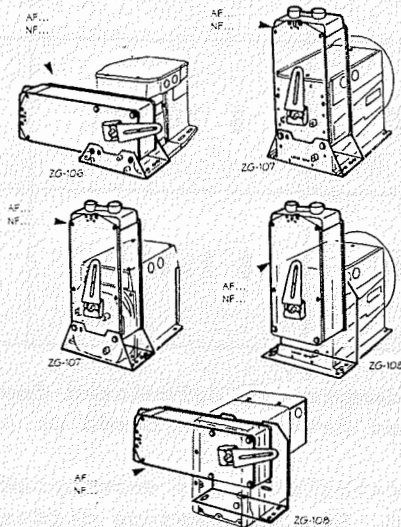

- ◆ Belimo can replace Barber Coleman MM and Johnson M series
- ◆ As of January 31, 1996 we will no longer be marketing Equimeter Gas Regulators. However we will continue to sell Equimeter meters.

### DESIGN TIPS:

#### MORE ON KITCHEN EXHAUST DUCTS:

Clearance to combustable material may be reduced if the combustable material is protected by the following:

- (1) *inch to combustable material:* 28 GA sheet metal spaced out on 1" on non-combustible spacers
- (2) *inches to combustable material:* 22 GA sheet metal on 1" mineral wool bats reinforced with wire mesh or equivalent spaced out 1" on non-combustible spacers
- (3) *inches to combustable material:* Fire Master duct wrap or Pabco board duct protection

"I've learned that how you do your work is a portrait of yourself"

- AGE 64

COMPLIMENTS:

# COST OF OWNERSHIP FOR TAMCO DAMPER

DAMPER SIZE	TAMCO 1000	TAMCO 9000	OTHER (WITH SEALS)	OTHER (NO SEALS)
48" x 48"	\$ 460.00	\$ 620.00	\$ 245.00	\$ 210.00
TOTAL LEAKAGE	75 CFM	60 CFM	160 CFM	640 CFM
ANNUAL HEAT LOSS	\$ 12.00	\$ 5.00	\$ 14.00	\$ 14.00
ANNUAL INFILTRATION LOSS	\$ 60.00	\$ 48.00	\$ 128.00	\$ 507.00
ANNUAL HUMIDIFICATION LOSS	\$ 56.00	\$ 45.00	\$ 120.00	\$ 480.00
1 YEAR COST OF OWNERSHIP	\$ 588.00	\$ 718.00	\$ 507.00	\$ 1211.00
5 YEAR COST OF OWNERSHIP	\$ 1100.00	\$ 1110.00	\$ 1555.00	\$ 5215.00

**NOTES:**

- 1) Leakage on Tamco dampers is calculated from latest AMCA certified published data. Other based on catalogue values.
- 2) Energy costs are calculated for unoccupied times when outside air dampers are closed. Static pressure differential is 1" WC.
- 3) \$ 5.00 per CFH gas
- 4) \$ 0.08 KW/HR electricity
- 5) Cost of ownership: initial cost plus annual operating costs.
- 6) Additional benefits for Tamco include:
  - ◆ longer life (20 years)
  - ◆ eliminates freezeup
  - ◆ low pressure drop